

# TopBrewer

Pre-installation guide



**TopBrewer Compact  
with Smart Fridge and Cooler**

# Installation Requirements



TopBrewer Compact



Smart Fridge



Cooler 45 | Chiller

UNIT DETAILS		TopBrewer Compact	Smart Fridge	Cooler 45   Chiller		
Installation Dimensions (WxDxH)		183 x 510 x 670 mm	230 x 390 x 530 mm	255 x 486 x 404 mm		
Packing Dimensions (WxDxH)		300 x 630 x 780 mm		265 x 483 x 464 mm		
Weight, gross.		41 kg	17,5 kg	22 kg		
Weight, net.		39 kg	15,5 kg	19 kg		
Bean/Carton Capacity		1.5 kg	Up to 9 L	-		
Throughput/hour		120 cups		45 L		
Approvals		CE, ETL/UL, CB, NSF	CE, ETL/UL	CE, ETL/UL, NSF		
Power		EU	220-240V AC Full Power: 20 amp, 4,6 kW Priority heating: 10 amp, 2,3 kW	208-240V, 50/60 Hz, 4 Amp 3-pin plug point for each unit.	220-240V AC, 10 amp plugpoint, for each unit	
Water		Direct Water Connection, 3/4" type shutoff valve Water pressure: 200kPa (2 bar) – 600 kPa (6 bar)		-	-	Direct Water Connection, 3/4" type shutoff valve Water pressure: 200kPa (2 bar) – 600 kPa (6 bar)
Filtration		TopBrewer water filters filled in a location adjacent to the TopBrewer. Dedicated steam filter required (Pure 50, 0% bypass). <i>See plumbing section</i>	TopBrewer ActiveCoal 10.000, optional, purities the water with active coal	-	-	TopBrewer ActiveCoal 10.000, optional, purities the water with active coal
Drainage		Waste U-pipe, Ø40mm. Manifold/drain plug (included, see <b>plumbing section</b> ) is inserted and components are connected here.				
Ventilation		Direct Fan Ventilation required. Cooler produces a lot of heat, which needs to be able to exit as per installation instructions in <b>carpenter section</b> .				

# Cabinet dimensions & ventilation cut-outs

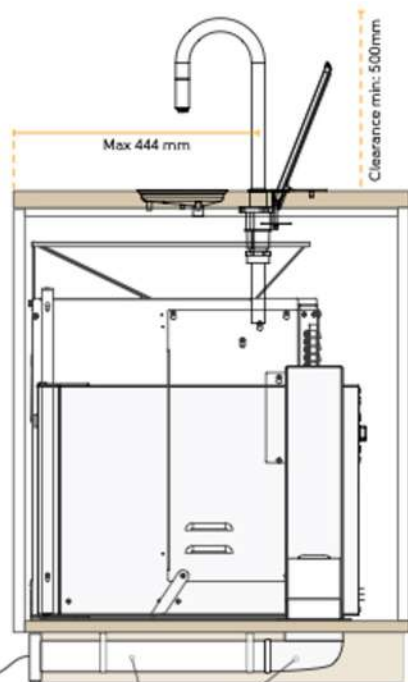

Flat Channel Duct + Angle  
Sold separately as SKU  
4302789 and 4302790

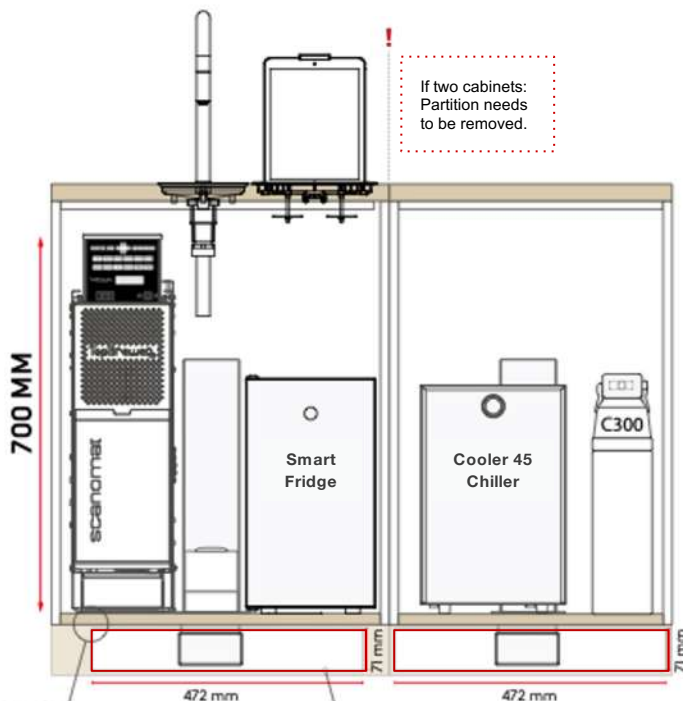

Example here using included aluminum grate.  
A custom design can also be mitigated.

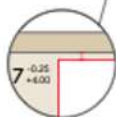

Side

Front

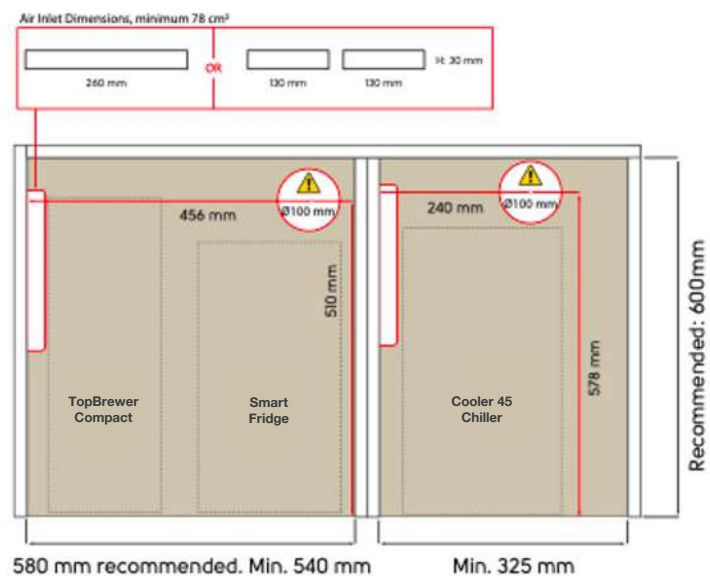
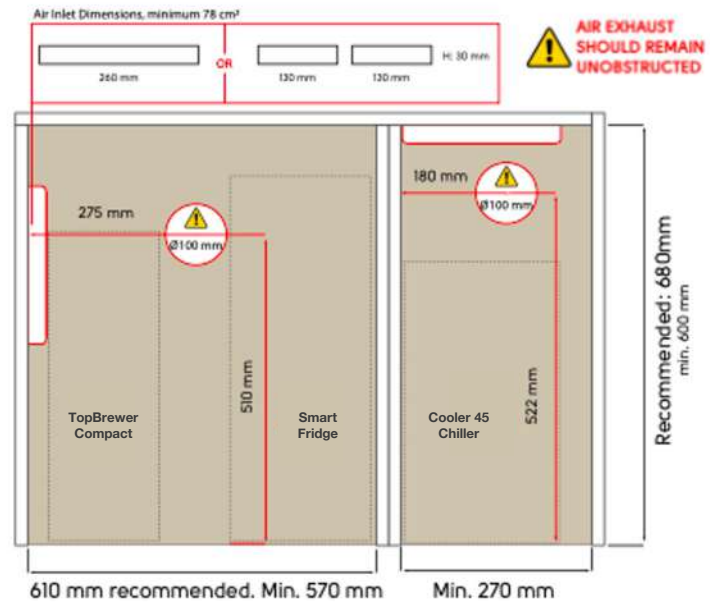

Top View

# Cut-outs in countertop for installation

Make sure the right iPad holder is specified before starting the work.





iPad Standard Holder

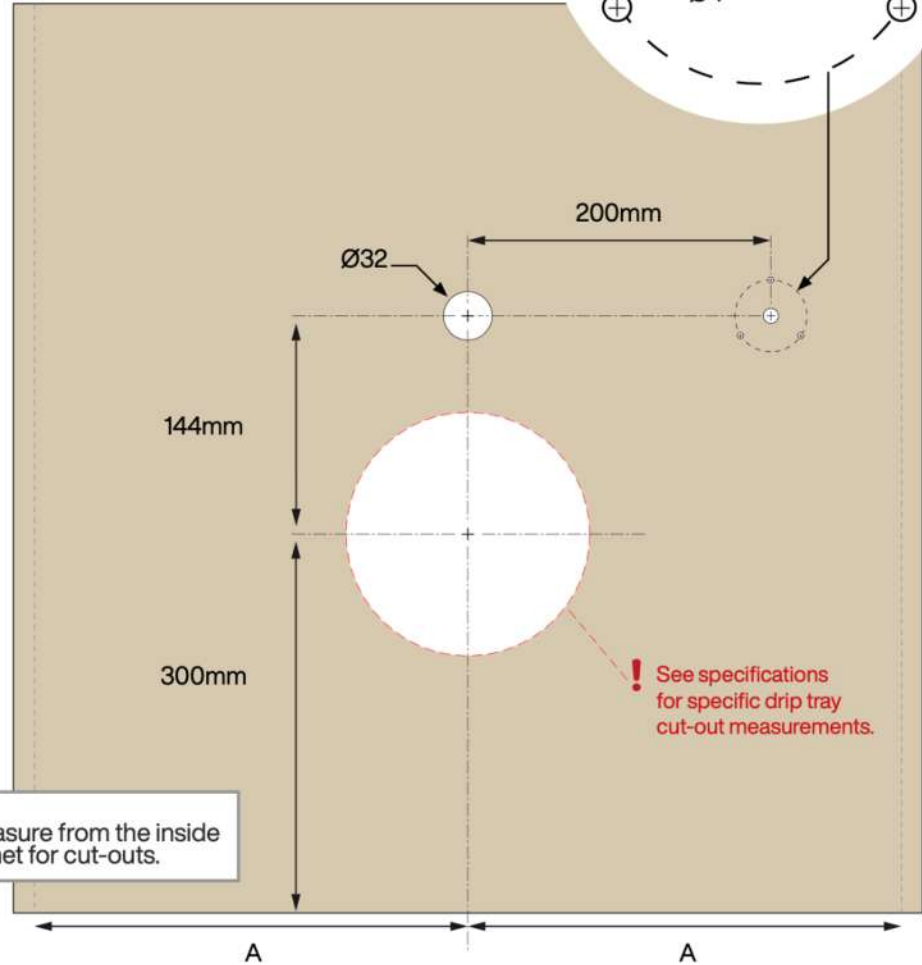
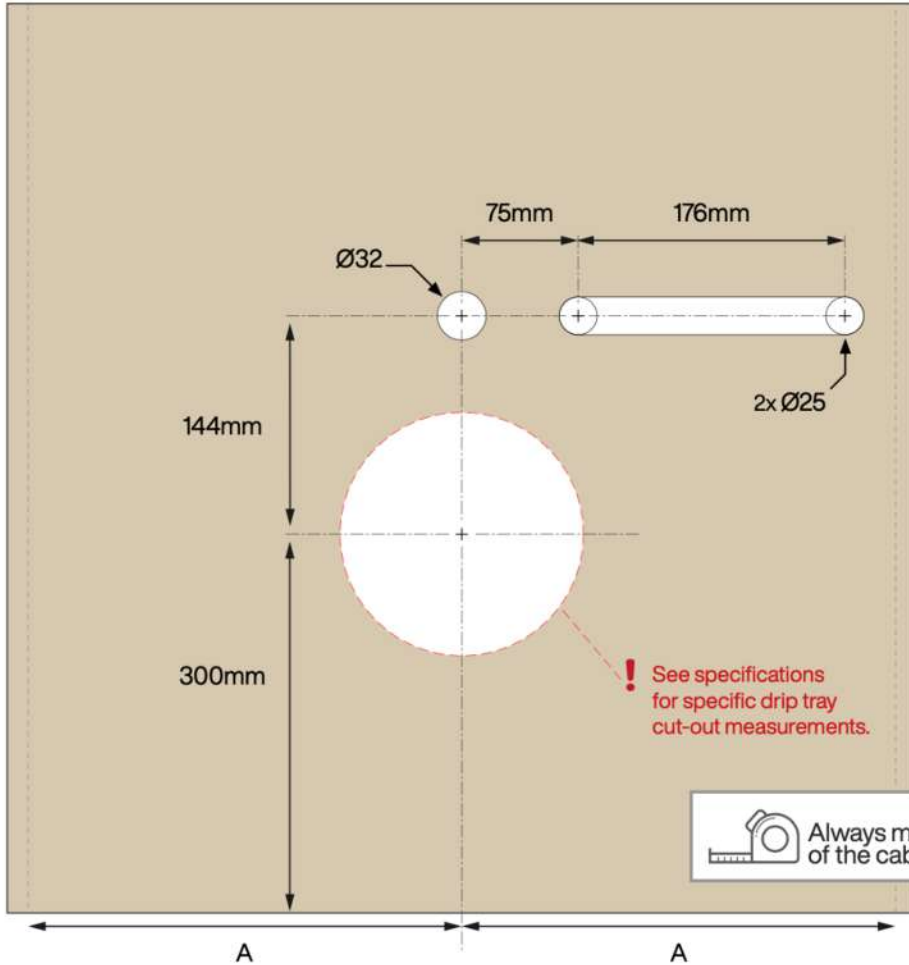
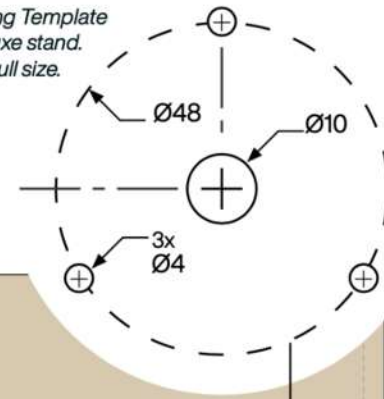

iPad Deluxe Holder

1:1 Drilling Template for iPad Deluxe stand. Print A4 full size.



 Always measure from the inside of the cabinet for cut-outs.

## Drip Tray Top-Mounted



Top-Mounted drip tray with lip is recommended for wooden countertops or countertops where the cut can only be made throughout.

SKU: 2006162A

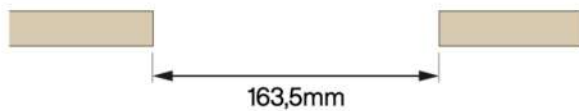
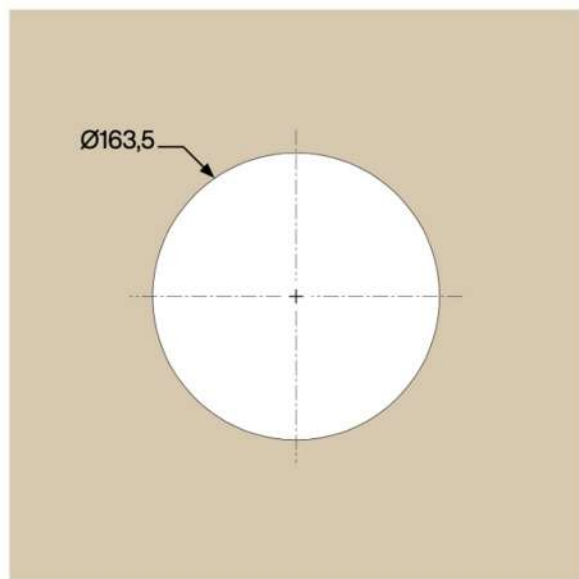

## Drip Tray Countersunk



Countersunk drip tray is recommended for solid countertops where the cut-out can be milled with a template.

SKU: 2006162

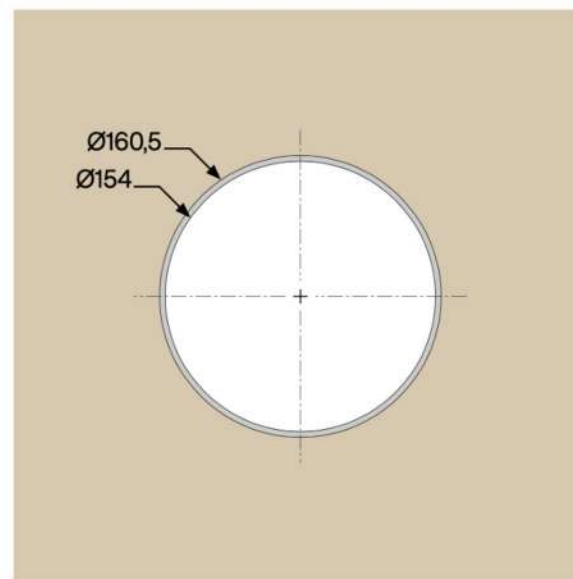



# Placement of electricity outlets in cabinet (EU Machine Installations)

The correct placement of the safety switch and power strips are important to ensure space for later installation of ventilation system and machines.

## Version 1

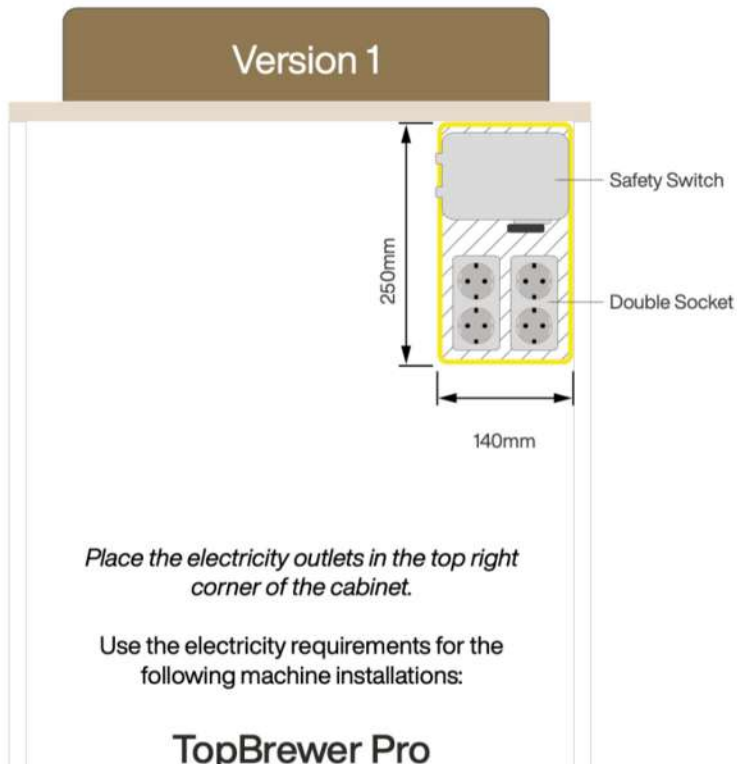

### TopBrewer Pro

3 phase	3 x 13A, 3P+N+E with Safety Switch.
1558EUV ER XX.XX	2x Double Socket - 230V, 1P+N+E, type Schuko.

### TopBrewer Compact

1 phase	1 x 20A (10A), 1P+N+E with Safety Switch.
1557EUV ER XX.XX	2x Double Socket - 230V, 1P+N+E, type Schuko.

## Version 2

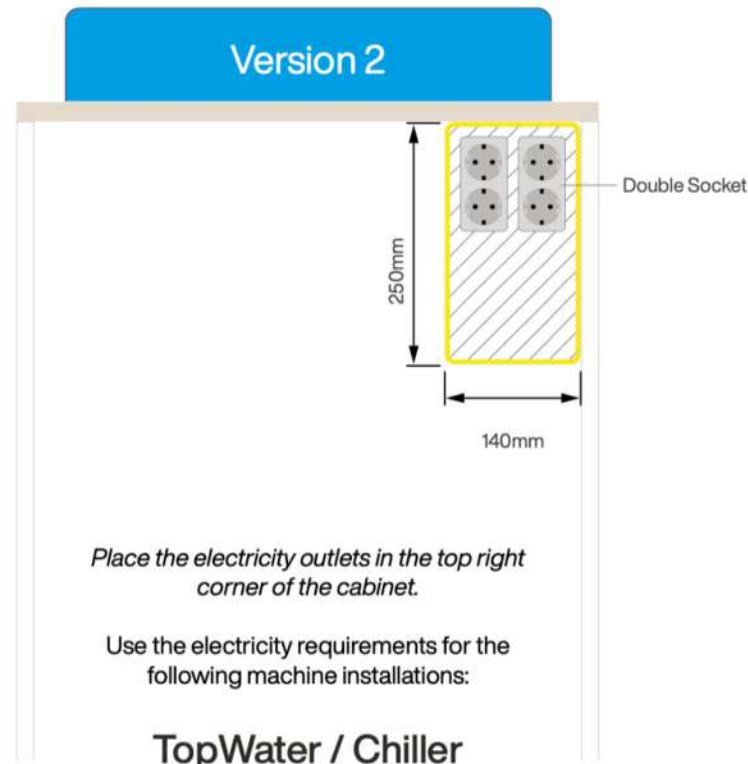





### TopWater / Chiller

1160EUV ER XX.XX	2x Double Socket - 230V, 1P+N+E, type Schuko.
------------------	---

**IMPORTANT**  
 Electrical installations to be placed with this area.

# Plumbing

-  **U-Pipe is required**
-  Drainline from driptray
-  Fridge waste water
-  Drainpump from machine
-  Main Water w/ shutoff valve

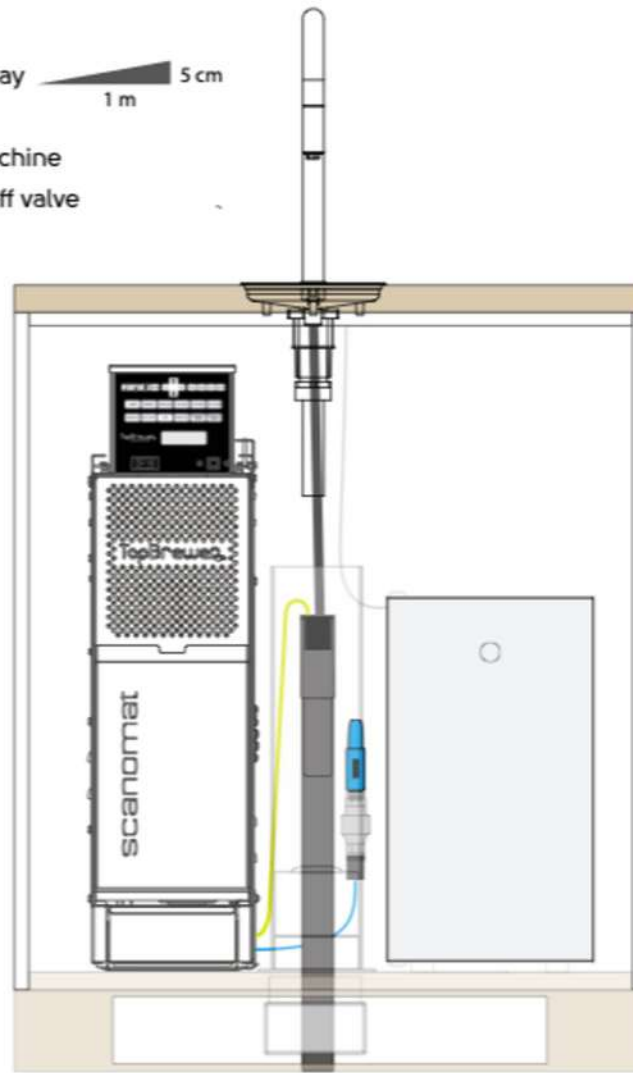
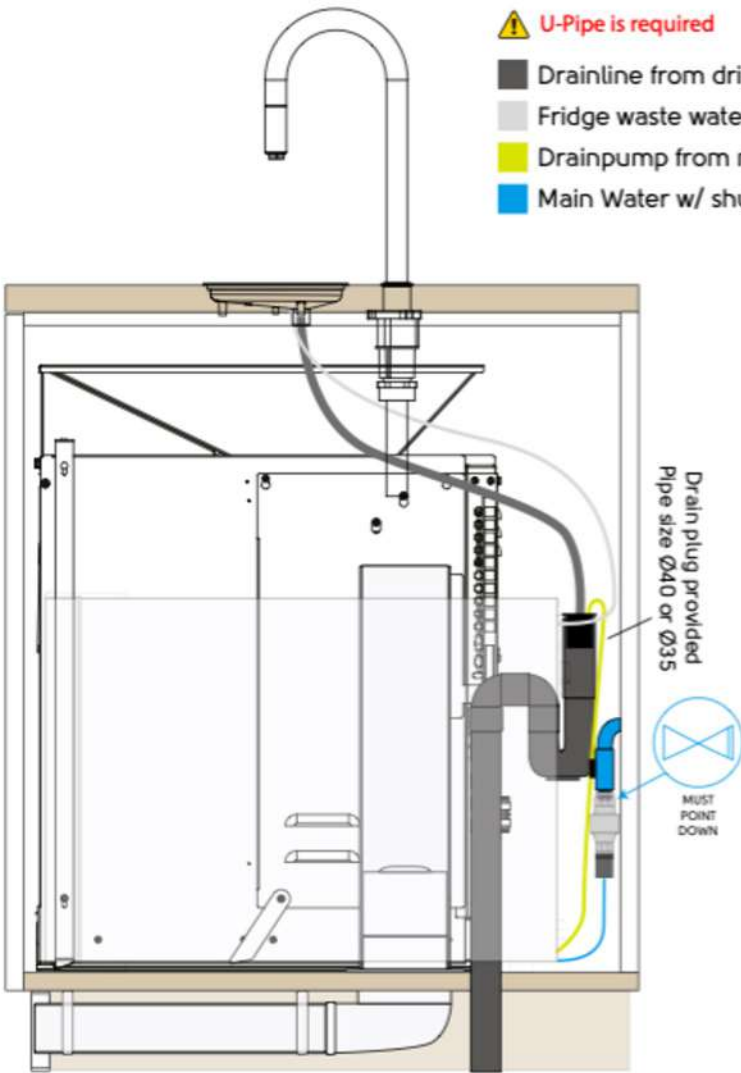

### Filters

Filters are chosen based on the projected usage pattern of the machine. Distance of installation relative to the machine are unlimited. An example of the capacity is listed below.

#### Capacity:

Example: 30% bypass, °dH. 15

- C150: 1390 L
- C300 2310 L
- C500: 2926 L

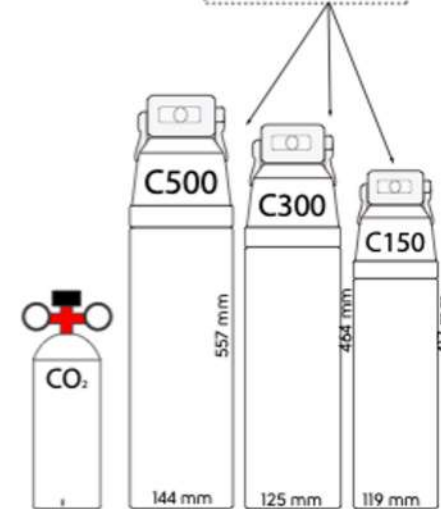

Optional CO<sub>2</sub> bottle placement. (if applicable). Must be standing upright, max pressure setting 3 bar.



Please reach out to us for additional questions!

T: 035-205 5049 | E: [service@topbrewer.nl](mailto:service@topbrewer.nl)